

CENTER OF
APPLIED SPACE TECHNOLOGY
AND MICROGRAVITY



BREMEN DROP TOWER PAYLOAD USER'S GUIDE

VERSION 1.3



VERSION HISTORY

| Version | Date | Author | Amendments |
|---------|----------------|--------------|---|
| 1.0 | - | T. Könemann | document finalization |
| 1.1 | March 01, 2022 | T. Könemann | release version of "Bremen Drop Tower - Payload User's Guide" and expiration of the validity of former "ZARM Drop Tower Bremen - User Manual" |
| 1.2 | May 13, 2022 | T. Könemann | revision of section 2.2 "The GraviTower Bremen Pro" based on improvements / general document revision |
| 1.3 | July 11, 2023 | M. Cornelius | general document revision / new high-speed camera system added / Inertial Measurement Unit (IMU) updated |
| | | | |
| | | | |
| | | | |

HOW TO READ THIS DOCUMENT

The present Payload User's Guide shall serve for both, as a general introduction to ZARM's microgravity facilities and a detailed document describing all mechanical and electrical interfaces, as well as the control software that you need to know before starting to design your drop tower experiment.

Your experiment can only be integrated in accordance with the given boundary conditions, thus, referring to this document is mandatory. Since our aim is to serve the experimenter's needs as best as possible, please contact us if you cannot find technical information that are important for you. Please keep in mind, that many items of technical equipment might have been already implemented upon former user's requests. Thus, we might already have a solution for your problem at hand.

DOCUMENT OWNER

ZARM Fallturm-Betriebsgesellschaft mbH | ZARM Drop Tower Operation and Service Company

- ZARM FAB mbH -

Handelsregister | Registration Court: Amtsgericht Bremen HRB 12600
Geschäftsführung | Executive Board: Prof. Dr. Marc Avila, Peter von Kampen

ADDRESS

ZARM FAB mbH
c/o University of Bremen
Am Fallturm 2
28359 Bremen
Germany

HOMEPAGE

www.zarm.uni-bremen.de

CONTACT PERSONS

Dr.-Ing. Thorben Koenemann

Leitung Wissenschaft und Betrieb | Head of Science and Operation
ZARM FAB mbH

Tel. +49 (0)421 218-57785

Fax +49 (0)421 218-57753

thorben.koenemann@zarm.uni-bremen.de

Dr. Merle Cornelius

Stellv. Leitung Wissenschaft und Betrieb | Dep. Head of Science and Operation
ZARM FAB mbH

Tel. +49 (0)421 218-57958

Fax +49 (0)421 218-57753

merle.cornelius@zarm.uni-bremen.de

ACRONYM LIST

| | |
|----------|---|
| ACE | Additional Capsule Equipment |
| AI | Artificial Intelligence |
| ASCII | American Standard Code for Information Interchange |
| CCS | Capsule Control System |
| COG | Center of Gravity |
| D-sub | D-subminiature - Electrical Connector |
| DTSP | Drop Tower Sensor Pack |
| EGSE | Electronic Ground Support Equipment |
| g | Gravitational Acceleration |
| GUI | Graphical User Interface |
| IMU | Inertial Measurement Unit |
| I/O | Input / Output |
| LabVIEW™ | Laboratory Virtual Instrumentation Engineering Workbench |
| Li-Fi | Light Fidelity (Network) |
| MOSFET | Metal-Oxide-Semiconductor Field-Effect Transistor |
| PDU | Power Distribution Unit |
| RCM | Release-Caging-Mechanism |
| SCE | Standard Capsule Equipment |
| SMA | SubMiniature Version A - Electrical Connector |
| TDMS | Technical Data Management System |
| USB | Universal Serial Bus |
| ZARM | Zentrum für angewandte Raumfahrttechnologie und Mikrogravitation Center of Applied Space Technology and Microgravity |

TABLE OF CONTENTS

| | |
|---|-----------|
| 1. About ZARM | 7 |
| 1.1 INTRODUCTION | 7 |
| 2. Facilities Overview | 8 |
| 2.1 THE BREMEN DROP TOWER | 8 |
| 2.1.1 - LABORATORY | 8 |
| 2.1.2 - CATAPULT SYSTEM | 10 |
| 2.1.3 - INTEGRATION HALL | 11 |
| 2.1.4 - CONTROL ROOM | 12 |
| 2.2 THE GRAVITOWER BREMEN PRO | 13 |
| 2.2.1 - LABORATORY | 13 |
| 2.2.2 - CONTROL DESK | 15 |
| 3. Experiment Operation | 17 |
| 3.1 LEAD TIME | 17 |
| 3.2 INTEGRATION PROCESS | 18 |
| 3.3 DROP / CATAPULT OPERATION | 18 |
| 3.4 GRAVITOWER OPERATION | 19 |
| 3.5 END OF CAMPAIGN | 20 |
| 4. Experiment Accommodation | 21 |
| 4.1 DROP TOWER CAPSULES | 21 |
| 4.1.1 - MOUNTING OF EQUIPMENT | 22 |
| 4.1.2 - PAYLOAD DIMENSIONS AND MASSES | 23 |
| 4.1.3 - MECHANICAL REQUIREMENTS | 24 |
| 4.1.4 - CATAPULT CAPSULE REQUIREMENTS | 24 |
| 5. Payload Interfaces | 25 |
| 5.1 STANDARD CAPSULE EQUIPMENT | 25 |
| 5.1.1 - CAPSULE CONTROL SYSTEM | 26 |
| 5.1.2 - BATTERY PACKS AND POWER DISTRIBUTION UNIT | 26 |

| | |
|--|-----------|
| 5.1.3 - ELECTRICAL INTERFACE BOARD AND CARDS | 28 |
| 5.1.4 - STANDARD CAPSULE SENSORS | 29 |
| 5.1.5 - INERTIAL MEASUREMENT UNIT | 29 |
| 5.1.6 - DROP TOWER SENSOR PACK | 29 |
| 5.2 ADDITIONAL CAPSULE EQUIPMENT | 30 |
| 5.2.1 - HIGH-SPEED CAMERA SYSTEMS | 30 |
| 5.2.2 - HEATING AND COOLING CIRCUIT | 32 |
| 5.2.3 - NON-STANDARD POWER SUPPLY | 32 |
| 5.2.4 - NON-STANDARD DC / AC CONVERTERS | 32 |
| 5.2.5 - CAPSULE VENT LINE | 33 |
| 6. Environmental Conditions | 34 |
| 6.1 PRESSURE ENVIRONMENT | 34 |
| 6.2 THERMAL CONDITIONS | 34 |
| 6.3. - ACCELERATION / DECELERATION PLOTS - DROP MODE | 35 |
| 6.3. ACCELERATION / DECELERATION PLOTS - CATAPULT MODE | 37 |
| 6.3.3 - ACCELERATION / DECELERATION PLOT - GRAVITOWER MODE | 39 |
| 6.3.4 - QUALITY OF MICROGRAVITY | 40 |
| 7. Safety | 41 |

1. ABOUT ZARM

1.1 Introduction

Since 1985, the Center of Applied Space Technology and Microgravity (ZARM) of the University of Bremen has been one of the most prominent scientific organizations in Bremen – the “City of Space”. Thanks to its broad experience and expertise, ZARM has established itself as an internationally renowned institute within the faculty of production engineering, and is recognized for its excellent academic education of young scientists.

Scientists from different disciplines, including engineering, physics, mathematics, and computer sciences, conduct research within the fields of fluid dynamics, space sciences, and space technology. The working groups at ZARM explore for example the behavior of fluids under conditions of microgravity, produce detailed computer simulations of space systems, and work on the implementation of satellite missions. With this interdisciplinary approach, and its unique drop tower facility, ZARM is a recognized partner for international cooperation.



ZARM AND THE BREMEN DROP TOWER

ZARM's 146-meter high Bremen Drop Tower is not only a technological landmark of Bremen but unique in Europe, and offers scientists from all over the world a cost-effective and permanently accessible option to perform experiments under space conditions. With its catapult system, the drop tower's 9.3-second duration in microgravity is the longest in the world. And with its GraviTower Bremen Pro, scientists are able to explore large parameter spaces by realizing almost 1000 experiments a day, not just limited to microgravity, but also involving partial gravity conditions.

Within the context of its test center capabilities, ZARM also operates the largest centrifuge in Europe, which enables tests and certifications of aerospace structures as well as prototypes under conditions of hyper gravity. In addition, the centrifuge is able to accommodate a drop tower capsule to investigate gravity-related phenomena from microgravity up to 30 g. Furthermore, space components can be tested under realistic settings in the in-house thermal vacuum chambers and the vibration test laboratory, in order to ensure in advance that they will be fully functional in space.

2. FACILITIES OVERVIEW

2.1 The Bremen Drop Tower

2.1.1 - Laboratory

The Bremen Drop Tower is the main laboratory of ZARM and the only laboratory of this kind in Europe. Since its inauguration in September 1990, it offers the most economic opportunity for short-term experiments during 4.7 seconds under highest-quality conditions in weightlessness, comparable to one millionth of the Earth's gravitational force (10^{-6} g). Since the implementation of the catapult system, a construction developed by ZARM engineers, the experiment duration has been extended to 9.3 seconds - unmatched by any other drop facility worldwide.

Due to its excellent microgravity conditions, the Bremen Drop Tower has received considerable international attention and is well occupied. Scientists from all over the world come to Bremen in order to experiment on different research fields like astrophysics, biology, chemistry, combustion, fluid dynamics, fundamental physics, and materials sciences as well as perform technology tests preparing and qualifying instruments for future space missions.

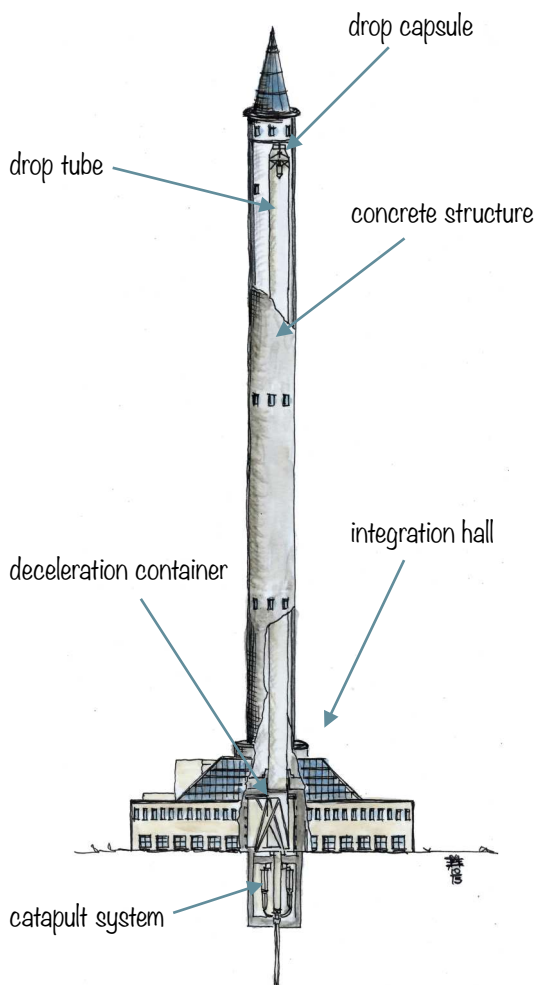

FACTS ABOUT THE DROP TOWER BUILDING

- height of the Bremen Drop Tower: 146 m
- diameter of the concrete structure: 8 m
- stairs: about 600 steps until the top

FACTS ABOUT THE DROP TUBE

- height of the drop tube: 120 m
- distance of free fall: 110 m
- diameter of the drop tube: 3.5 m
- deceleration container: filled with 15 m³ of polystyrene pellets up to a height of 8.20 m
- experiment duration in microgravity:
 - drop experiment - 4.7 s
 - catapult experiment - 9.3 s
- maximum capsule speed: 168 km/h
- total weight of standard capsule: 500 kg
- vacuum: 18 pumps draw out 1,700 m³ of air in 1.5 to 2 h
- pressure after evacuation: 10 Pa (0.1 mbar)
- achievable microgravity quality: 10^{-6} g
- number of drops or catapult launches: up to 3 times a day

Figure 2.1: Layout drawing of and basic facts about the Bremen Drop Tower.

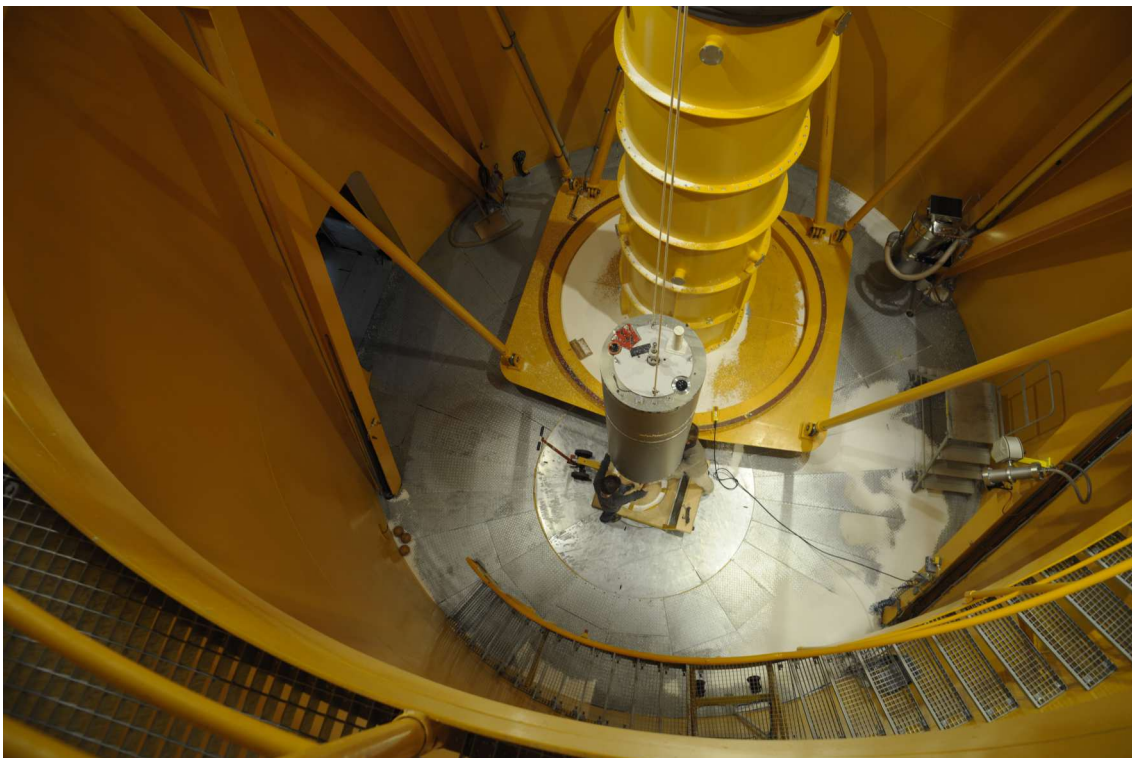
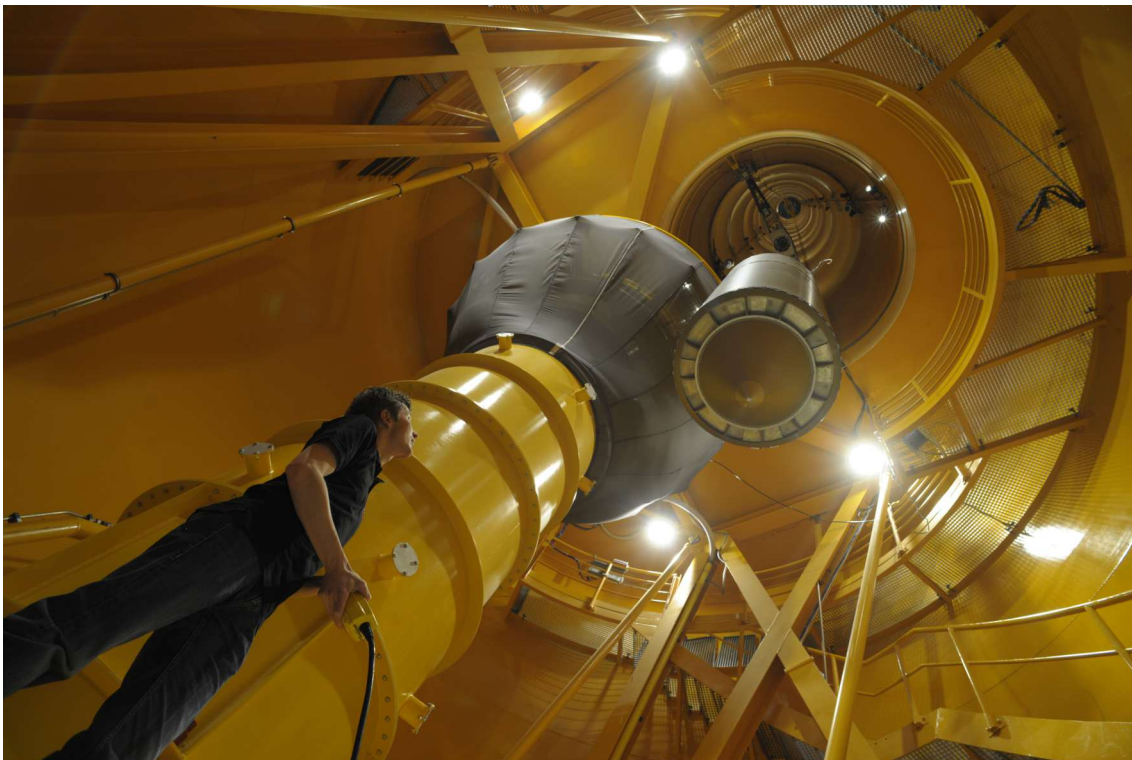

Figures 2.2: Bottom-up [top] and top-down view [bottom] from inside of the deceleration chamber - with deceleration container, drop tube, and experiment capsule during drop preparation.

2.1.2 - Catapult System

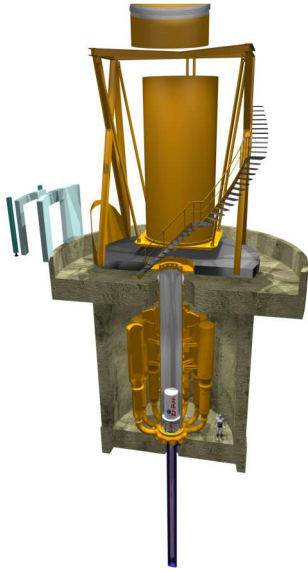

When breaking ground for the Bremen Drop Tower in May 1988, the installation of a catapult system underneath the building had already been taken into account. 16 years later, the ZARM engineers finished designing the catapult system and it was inaugurated in December 2004.

The pneumatically driven and hydraulically controlled system takes 0.25 seconds to accelerate the experiment capsule to a speed of 168 kilometers per hour. The exact force of acceleration is being calculated for each individual experiment in order to catapult the capsule as close as possible to the top of the drop tube and thus maximize the duration of the flight. After a couple of seconds the deceleration container has already been moved into place, again, in order to catch the capsule on its way down.

By doubling the trajectory length the catapult system is capable to extend the time period spent in microgravity to 9.3 seconds - an experiment duration no other drop tower facility can provide.

Figure 2.3: Layout drawing of deceleration chamber and catapult cellar.

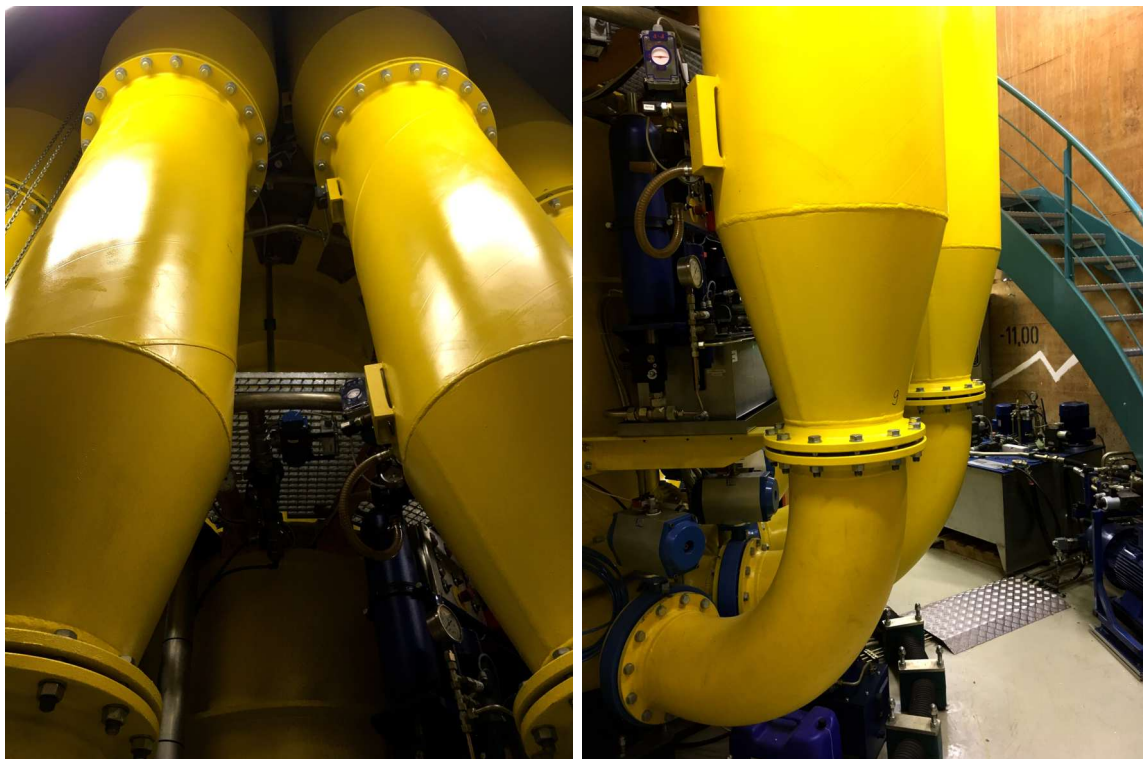

Figures 2.4: [left] Air tanks in the front and catapult cylinder behind them.
[right] Hydraulic pump units at the right rear side.

2.1.3 - Integration Hall

Experimenter's main workplace is the integration hall surrounding the drop tower. Each microgravity experiment gets its dedicated integration area with workbenches, tools, and an Electronic Ground Support Equipment (EGSE).



Figure 2.5: Experimenter's integration area for preparing the drop tower experiment.

The EGSE consists of standard power supplies as well as dedicated communication and control units. It delivers the identical mechanical, electrical, and software interfaces as in the drop tube.

Its control computer is connected to a private client / server network hosting experimenter's specific password-protected user account. In this manner, any changes made at the EGSE are automatically implemented in the drop tower routine, too. Thus, the drop tower user is able to perform ground experiments with the fully integrated capsule following the identical procedure as during drop tower operation and under similar technical conditions (except microgravity conditions, of course). If necessary, air-conditioned laboratories, e.g., to operate classified laser systems, or even clean rooms can be made available.

Figure 2.6: EGSE-to-capsule interface unit.



2.1.4 - Control Room

During drop tower operation, experimenters have a permanent remote access to their experimental setup in the capsule. The communication between control room and experiment capsule, which is located in the drop tube at this stage, is realized via a professional telemetry / telecommand transmission path. After logging in on experimenter's specific password-protected user account, the ground control computer based on a National Instruments™ program visualizes the software interface and remotely control the microgravity experiment. All received data and transmitted commands are in situ monitored with the assistance of NI's software interface, as well as securely stored in the related user account on the local and private network server of the Bremen Drop Tower.



Figure 2.7: Control room of the Bremen Drop Tower.

The responsible drop tower engineers operate and monitor all drop tower systems from the control room. It shall be emphasized at this point that they still assist the experimenters during their experiment operation.

- ➔ Please note: Once the drop tower is ready for dropping or launching the experiment capsule, the responsible operators will open a drop / catapult launch window for several minutes enabling the experimenters to start their experiment sequence and thus drop / launch the capsule by themselves. There will be no specific countdown.

2.2 The GraviTower Bremen Pro

2.2.1 - Laboratory

Since the beginning of the year 2022, the GraviTower Bremen Pro represents ZARM's new next-generation drop tower system, which makes use of a rail-guided rope drive being able to perform over 80 short-term microgravity experiments per hour. Even enabling partial-gravity will be possible in the future. Its technology is based on a commercial hydraulic winch system with more than 4000 hp of engine power that moves a rail-guided slider in a 16 m high tower, upwards and downwards.

With its novel and sophisticated Release-Caging-Mechanism (RCM), the actively driven GraviTower located in the integration hall of the Bremen Drop Tower is capable to control heavy payloads in a very smooth and precise manner. The RCM developed and patented by ZARM also enables a fast and reliable decoupling as well as re-coupling of the experiment capsule inside the slider, which acts as a drag shield. Due to the fact that the Standard Capsule (see section 4.1.) of the Bremen Drop Tower is utilized, high synergy effects are given between both, the Bremen Drop Tower and GraviTower Bremen Pro. It means a simple switching between all operation modes (drop, catapult, or GraviTower) with the same experiment capsule.

Furthermore, GraviTower's user-friendly software control interface and future artificial intelligence (AI) capabilities interacting with the experimental setup now bring experimenting under space conditions on a laboratory level.

In conclusion, the GraviTower Bremen Pro excellently complements the Bremen Drop Tower and offers to explore a wide range of parameters, to test preliminary setups or experiment components, to qualify new technologies for space and / or exploration missions, or to facilitate dedicated microgravity and partial-gravity research with a very high repetition rate.

➔ Please note: Partial-gravity experiments and artificial intelligence operated at full system capacity will be feasible after next development stage.

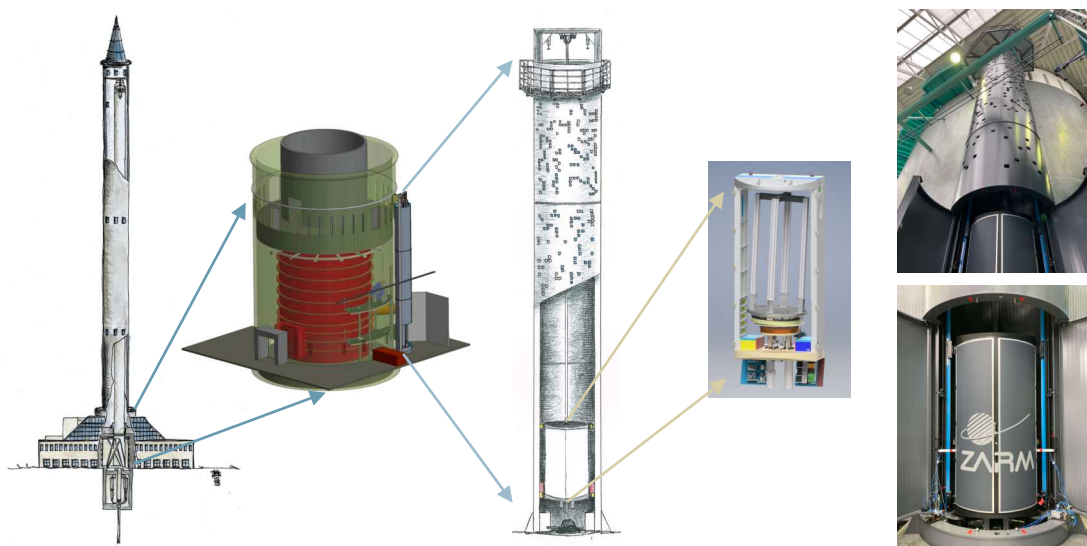

Figure 2.8: Location of the GraviTower Bremen Pro in the integration hall of the Bremen Drop Tower.



Figure 2.9: View inside GraviTower's open slider - with Standard Capsule on RCM.

FACTS ABOUT THE GRAVITOWER BREMEN PRO

The GraviTower

- allows a tested repetition rate of at least 80 runs per hour (over 960 experiments a day).
- provides a period of up to 2.5 seconds in microgravity depending on the initial acceleration and deceleration.
- has a proven quality of weightlessness that is better than 10^{-4} g.
- performs a smooth experiment transition into the free-fall phase based on a patented release technology that is realized with the so-called Release-Caging-Mechanism (RCM).
- enables users' adjustments of its kinematic parameters like individual amplitudes of the acceleration / deceleration profile (up to 5 g in total) - the related microgravity duration will be automatically calculated by the system.
- involves a software control interface with an intuitive Graphical User Interface (GUI) .
- is designed for the same Standard Capsule as in the Bremen Drop Tower with a total mass of up to 500kg.
- realizes a fast and easy access to the utilized capsule and experiment between runs, which takes only about 10 seconds.
- offers a high synergy effect with the Bremen Drop Tower to change between all operation modes (drop, catapult, and GraviTower) with the same experiment.

➡ Please note: The acceleration and deceleration values which are given here are the total acceleration levels. In contrast, the GraviTower Bremen Pro requires dynamical acceleration values for setting the kinematic parameters.

2.2.2 - Control Desk

Next to the GraviTower that is located in the integration hall of the Bremen Drop Tower, a dedicated control desk contains all control units to operate both, the GraviTower and the related experiment. GraviTower's user-friendly software control interface (Figure 2.10) provides a programmable Graphical User Interface (GUI) to have access to and adjust all needed kinematic parameters like the amplitude of initial acceleration and deceleration, as well as an optional function to optimize the transition into the free-flight phase. The same control interface is used to initiate the required procedures to finally launch the slider with the experiment capsule inside. In order to communicate with the experimental setup that is integrated in the standard drop tower capsule and connected to the RCM inside the drag-shield of the GraviTower at that time, an industrial Li-Fi (Light Fidelity) network is established. It realizes a secured optical and wireless telemetry / telecommand transmission path between the GraviTower and the experiment capsule.

Similar to the experiment operation with the Electronic Ground Support Equipment (EGSE) in the integration hall and from the control room of the Bremen Drop Tower (please refer to sections 2.1.3 and 2.1.4), the ground control computer based on a National Instruments™ program visualizes the software interface and remotely control the GraviTower experiment. In order to get access to the ground control computer, a login on experimenter's specific password-protected user account is required as usual. With the assistance of NI's software interface, all received data and transmitted commands are in situ monitored as well as securely stored in the related user account on the local and private network server of the Bremen Drop Tower.



Figure 2.10: Excerpt of the intuitive Graphical User Interface (GUI) of GraviTower's Software Control Interface - view of the actual tab with the adjustable kinematics by means of the acceleration and deceleration plotter.

- ➔ Please note: The GraviTower allows a fast and easy access to capsule and experiment between runs. During that period, it is possible to supply both, e.g., with electrical power, fluids, etc., or exchange experiment components.
- ➔ Please also note: A simplified version (Matlab/Python) of the script to calculate the possible flight trajectory can be provided for the experimenters prior to the microgravity campaign. Thus, the experimenters can evaluate the parameters of the flight kinematics in respect to the requirements of the experimental payload.

3. EXPERIMENT OPERATION

In the following, the procedure of the experiment operation during a microgravity campaign and the necessary preparations will be explained. Each microgravity campaign is unique and its duration depends highly on the conducted experiment, thus, only a typical example for a time plan can be given in Figure 3.1.

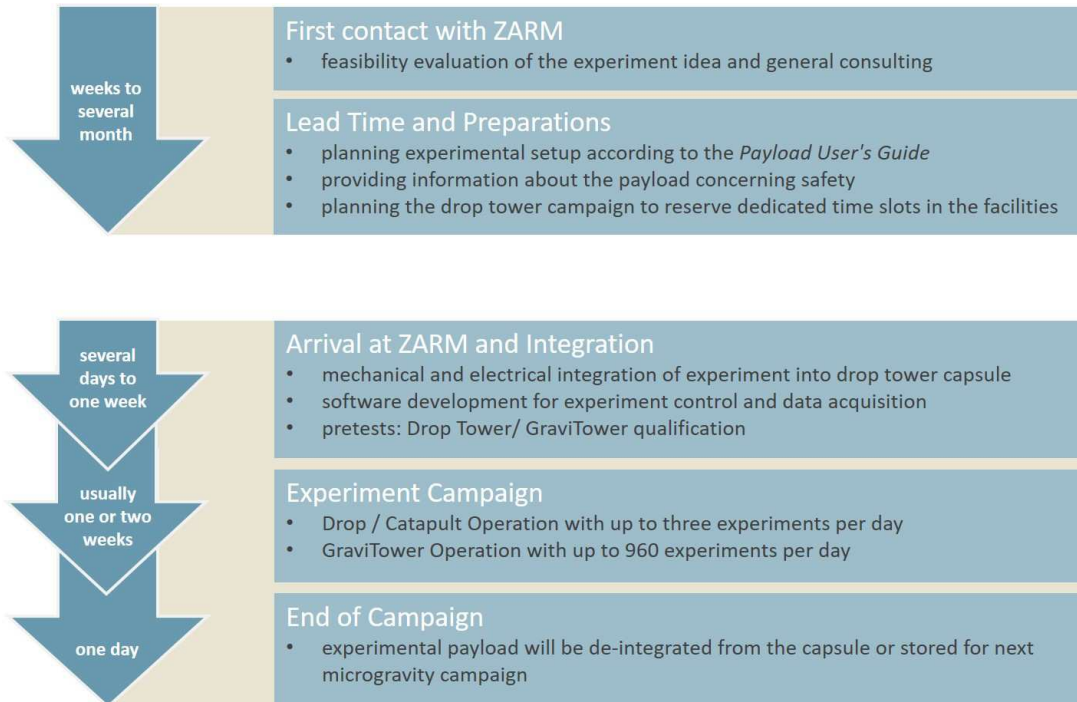

Figure 3.1: Rough time frame for conducting experiments in the drop tower.

3.1 Lead Time

The range of research fields and thus experiments capable to be performed in the Bremen Drop Tower and GraviTower Bremen Pro is very broad. The lead time certainly varies from experiment to experiment and depends on the complexity of the specific setup. Hence, the overall process accomplishing your planned drop tower project must be understood as a kind of prototype development. Nevertheless, there are examples in both directions - a lead time with only days or a few weeks on the one hand and several months or even years on the other hand.

As part of our service, ZARM FAB mbH assists the experimenters in all organizational measures as well as technical aspects from the first idea to the design to the assembly to the final realization of the drop tower campaign on site. For this, you can rely on the long-term expertise of ZARM FAB mbH in giving technical support to experimenters and integrating different types of microgravity experiments.

➔ Please note: Each experimenter is kindly requested to contact us as early as possible. Following this and as part of our service, each drop tower project will be accompanied by two drop tower engineers, one expert in mechanical

and one expert in electrical matters, working as a team together with the experimenters during all project stages - experiment preparation, integration process, and drop tower campaign.

3.2 Integration Process

After scheduling your drop tower campaign, you are usually expected to arrive at the drop tower min. 5 working days before the first flight. Such a period is needed for integration and ground testing as well as qualification of the experiment. As the operation is along a strict schedule, the decision about the duration of the integration process depends on the efforts required to assembly and connect the experimental setup inside the drop tower capsule and its qualification process to be fully operational. This duration is finally determined by ZARM FAB mbH personnel. For additional campaigns with the same setup, the integration period can be reduced as appropriate.

3.3 Drop / Catapult Operation

The drop tower is operated with three flights per day (not necessarily with the same experiment) on working days at the maximum. Each cycle to perform one flight calculated from handover of the capsule to the drop tower engineers until handover from drop tower engineers back to you lasts 4 hours including safety margins.

1. *From handover to drop or catapult launch, a period of about 2 hours should be considered. The handover times are 8 a.m., 12 a.m., and 4 p.m.. A delayed handover for more than 30 min. due to the experimenters' responsibility will lead to cancellation of the flight from schedule. Therefore, you are encouraged to carefully monitor the preparation time you need, before scheduling a drop tower campaign. Nevertheless, we will try to handle such a situation to your satisfaction. You are kindly requested to keep this policy in mind as being mandatory.*
2. *After handover, the capsule will be closed, connected to the winding mechanism and lifted to the top of the drop tube / positioned on the catapult piston. During this process, you have no remote access to the experiment for about 15 min. After reaching the upper end of the drop tube / positioning on the catapult piston, all external supply connections (battery charging, fluid supply, etc.) are established. The telemetry / telecommand communication enabling remote access from the control room to the capsule is also established. The experiment is now connected to all drop tower interfaces.*
3. *About 2 hours after handover to the operator, the evacuation process is finished with achieving the final pressure of about 10 Pa inside the drop tube. Then, the external supply units (battery charging, fluid supply, etc.) shall be disconnected.*
 - A. *In the dropping case, the experimenters now take over operation. They give the command to disconnect the external supply units (battery charging, fluid supply, etc.) and can drop the capsule whenever ready. Experimenters and operator are working in the same control room and can easily agree on the final procedure.*

or

B. In case of catapult flight, the catapult system is going to be armed approx. 10 minutes prior to launch. At this time, the external supply units (battery charging, fluid supply, etc.) must be disconnected. The catapult piston with the capsule is moved down to the launch position. After enabling by the drop tower operator, the catapult launch will be initiated by the experimenters within a time window of several minutes.

- 4. After capsule deceleration, all experiment data are stored on board or downloaded for evaluation via the telemetry / telecommand communication. In parallel, the drop tube is re-flooded with air.*
- 5. About 45 min. later, the capsule has been recovered from the deceleration container, opened, and handed back to the experimenters. Then, the final user data storage and inspection of the capsule takes place. Immediately after this, the experiment can be made ready for a further flight, if applicable.*

3.4 GraviTower Operation

The GraviTower Bremen Pro offers a very flexible experiment operation which is oriented on experimenting on a laboratory level or similar to that. For this, GraviTower's control desk (please refer to section 2.2.2) allows a full control of both, the GraviTower facility and the experiment by its users - the experimenters and the assisting drop tower engineers. The provided software control interface with its intuitive Graphical User Interface (GUI) is capable to operate the GraviTower runs. Furthermore, a fast and easy access to the experiment capsule and thus the experimental setup inside the GraviTower is guaranteed between each run. Performing a GraviTower run is theoretically feasible approx. every 45 seconds, which means over 80 GraviTower runs per hour and 960 a day.

During the GraviTower utilization, the experimenters remotely control their experiment inside the capsule from the ground control computer at the control desk. The ground control computer enables an operation of the GraviTower experiment that is similar to the Electronic Ground Support Equipment (EGSE) in the integration hall and from the control room of the Bremen Drop Tower (please refer to sections 2.1.3 and 2.1.4).

➡ Please note: For quantification purposes, a duration of four hours of GraviTower utilization will be counted as one flight in comparison to the drop or catapult operation in the drop tube of the Bremen Drop Tower. In this case, no changes in counting result, especially by possible changes between the desired operation modes - drop, catapult, or GraviTower - during a drop tower campaign. Each GraviTower utilization period lasting those four hours shall be understood as a GraviTower half-day. Such a half-day is the minimal counting unit for the GraviTower mode, which can be requested by the experimenters and starts with the handover of the experiment capsule for integration into the GraviTower at 8 a.m., 12 a.m., or 4 p.m. In terms of the administrative relevance of finally performed GraviTower runs within one or even more half-days, it does not matter how many actual runs would have been realized in total.



3.5 End of Campaign

At the end of a drop tower campaign, the experimental setup will be usually de-integrated from the used capsule structure. In case of a potential successive campaign, a partial de-integration of equipment or a storage of the fully integrated capsule at drop tower facility can be considered depending on experimenters' needs.

4. EXPERIMENT ACCOMMODATION

4.1 Drop Tower Capsules

All experiments are accommodated inside a specially designed drop tower capsule. According to the payload size, two different capsule versions are available, a shorter *Standard Capsule* and a *Long Drop Capsule*. While the Standard Capsule can be used for drop, catapult, and GraviTower operation, the Long Drop Capsule is only available for drop mode. Each capsule is pressurized to atmospheric pressure (in case of drop or catapult operation) as well as shockproof, in order to withstand the acceleration / deceleration forces. The main capsule components are:

- *capsule platforms (variable number / flexible distances) for the accommodation of experiment equipment*
- *four stinger rack (Bosch Rexroth aluminum profiles) for stacking the experiment platforms by brackets*
- *pressure-tight capsule cover with nose cone and lid plate including customized interfaces (drop / catapult)*
- *capsule base structure, which consists of the Standard Capsule Equipment (SCE)*

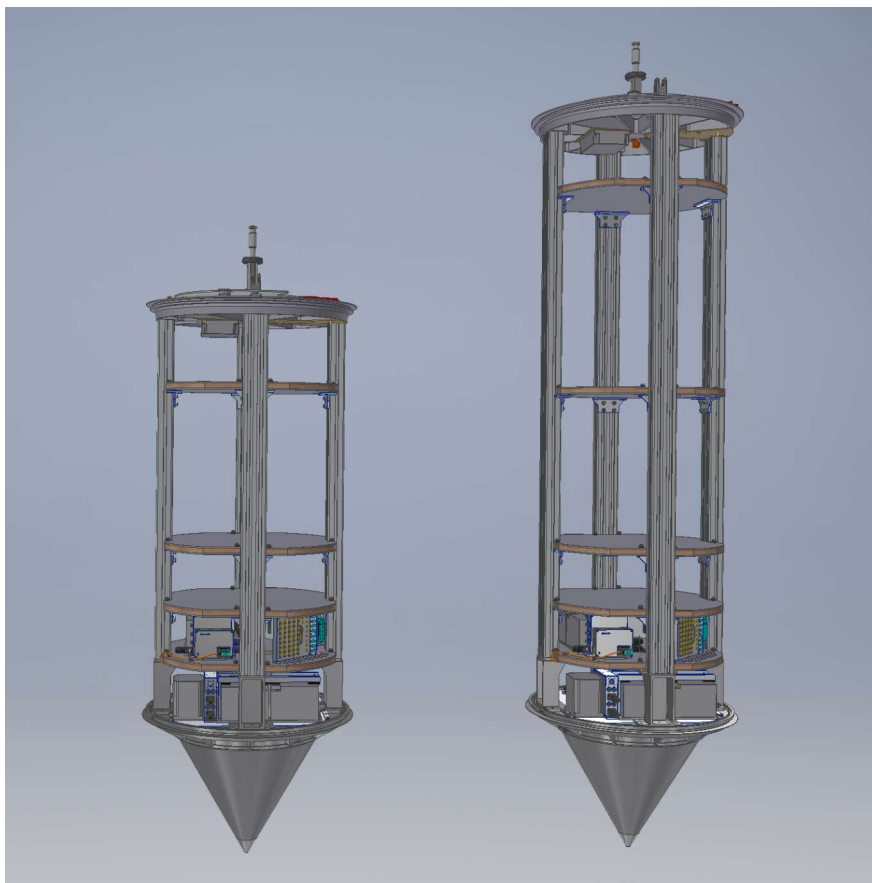

Figure 4.1: Drop tower capsule versions equally equipped with the Standard Capsule Equipment (SCE).

[left] Standard Capsule for drop, catapult, and GraviTower operation. [right] Long Drop Capsule.

➔ Please note: Upon special request, a non-standard capsule version consisting of two stacked Standard Capsules can be offered for drop operation additionally enlarging the payload dimension in height.

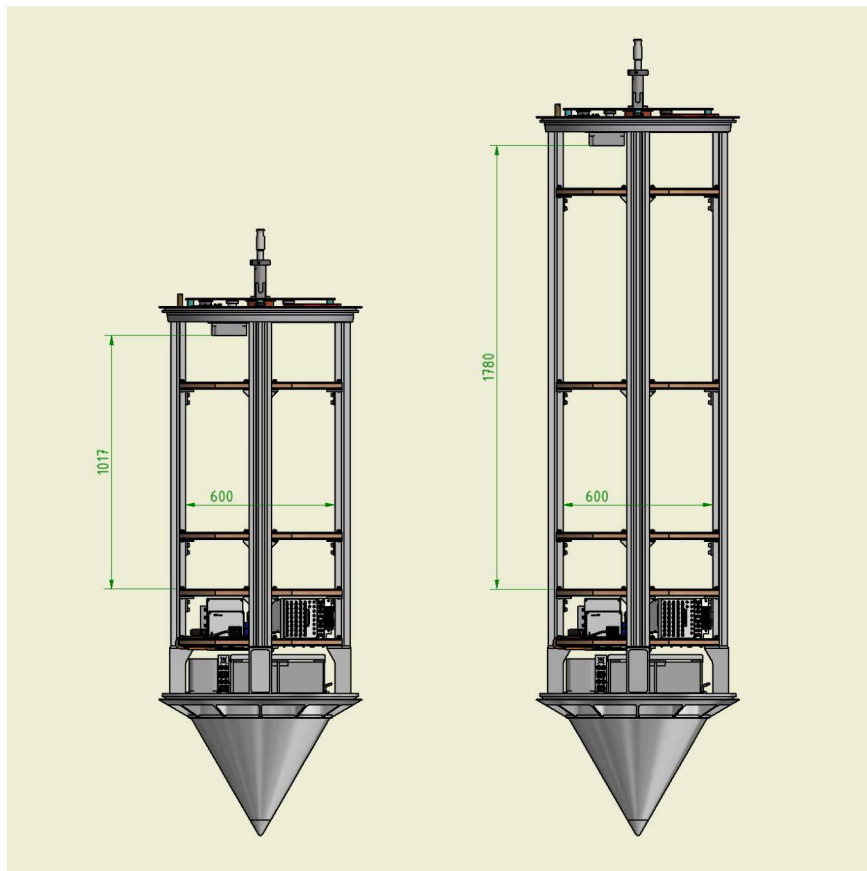

Figure 4.2: [left] Standard Capsule and [right] Long Drop Capsule with payload dimensions (safety margins are required). Number of experiment platforms are variable. Distances between them are flexible.

4.1.1 - Mounting of Equipment

Mechanical integration of payloads is made on specially designed sandwich-platforms of an aluminum (5 mm) / plywood (18 mm) / aluminum (5 mm) compound. Those provided capsule platforms can withstand the deceleration forces and serve for rapid damping of induced oscillations after capsule release. Experiment equipment can be fixed on or underneath the platforms within the payload area. It is even possible to create thru-holes into platforms in case of large assemblies. Each stringer can be used for further mounting purposes or cable run between platforms as well. The number of platforms and the distances between them depend on the specific drop tower experiment.

➔ **Important note:** It is permitted to drill holes or threads into the capsule platform, but it is not permitted to open the outer contour (e.g., by sawing into the platform from outside). In any case, capsule platform machining by experimenter shall only be conducted upon consultation of drop tower engineers. Delivery of appropriated number of capsule platforms to experimenter's premises can be arranged, if required.

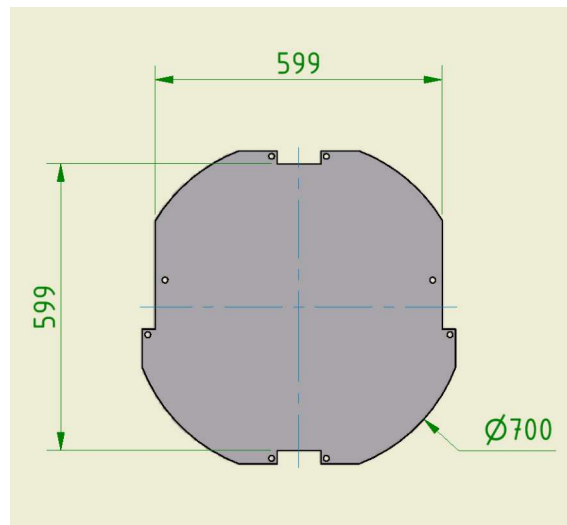

Figure 4.3: Drawing of a capsule platform with its dimensions and surface area which can be modified for mounting payloads. Its aluminum / plywood / aluminum compound structure allows thru-holes and thread holes.

4.1.2 - Payload Dimensions and Masses

| Operation Mode | Drop | | Catapult | GraviTower |
|---|----------------------|------------------|----------|------------|
| capsule version | Long Drop Capsule | Standard Capsule | | |
| max. payload height | 1780 mm | 1017 mm | | |
| max. payload diameter (between stringers) | 599 mm | | | |
| max. payload width (off stringers) | 700 mm | | | |
| total area of capsule platform | 0.359 m ² | | | |
| height of capsule platform | 28 mm | | | |
| weight of capsule platform incl. brackets | 15.5 kg | | | |
| capsule total weight [kg] | 500 kg | | 400 kg | 500 kg |
| payload mass [kg] | 225 kg | 265 kg | 165 kg | 265 kg |

➔ Important note: All dimension limitations are hard limits. It is mandatory to keep a safety distance from these limitations. If an experiment design exceeding the mass limit is required, it will be subject to special consulting.

4.1.3 - Mechanical Requirements

In order to mechanically design a drop tower experiment, the following technical limitations must be strictly kept:

- **The overall weight of a capsule platform (including the platform mass itself) may not exceed 100 kg.**
- **Point load of a capsule platform (to the center) may not exceed 50 kg.**
- **The distribution of payload mass should be evenly. The mass eccentricity should be as low as possible. (If the mass eccentricity is too high, additional counterbalance masses accumulated to the payload mass must be mounted to the stringer rack.)**

In drop and catapult mode, each payload has to withstand deceleration forces up to a peak value of about 50 g, and initial acceleration forces up to a peak value of about 30 g only during catapult operation. These peak values must be handled as quasi-steady accelerations. Finally, the introduction of a safety factor of 2 is strongly recommended. **Therefore, all capsule payloads shall be able to withstand accelerations of about 100 g (100% safety margin included) in drop tower operation, at least. In GraviTower operation, max. accelerations of only about 5 g in total occur. Thus, exclusively GraviTower payloads may adapt to that level - please refer to section 5.3 for examples of related capsule acceleration and deceleration plots.**

➔ **Important note: Shock absorbers within the experimental setup shall be avoided. In general, industrial shock absorbers are designed against shock (e.g., military standards), where the actual acceleration / deceleration is of a quasi-steady type (please also refer to section 5.3). Therefore, industrial shock absorbers might lead to an amplification of accelerations as they delay damping of the payload. The damping of a payload will be the best, the more rigid it is connected to the capsule platform / structure. No damping elements are recommend.**

Commercially available hardware may be used, but an absolute guarantee of its functionality during drop tower operation cannot be given, of course. Based on experience, a variety of qualified (laboratory) equipment that can be requested has been identified so far. It is strongly recommended to contact us for further information in this matter.

4.1.4 - Catapult Capsule Requirements

Due to safety requirements in the catapult operation mode, it is mandatory to tare the entire catapult capsule. The procedure of taring will take about 4 hours and will be performed by drop tower engineers on site after the experimental setup has passed its qualification review and before the first catapult launch. The technical reason is that the center of gravity (COG) has to be within a circle of 1 mm in diameter around the vertical geometrical catapult capsule center line. Therefore, all disassembling and reassembling of equipment inside the capsule during a catapult campaign must also be done without shifting the COG outside this tolerance circle. If the capsule setup does not fulfill the stated requirements above, a rebalancing will be necessary before the next catapult launch.

➔ **Important note: Especially for catapult experiments it is obligatory to design a rigid mechanical setup which is able to withstand the initial acceleration forces without any displacement of assembly parts. Cantilever beams or any kind of systems that might oscillate during the capsule acceleration phase must be avoided.**

5. PAYLOAD INTERFACES

5.1 Standard Capsule Equipment

The Standard Capsule Equipment (SCE) consists of the Capsule Control System (CCS) including its interface board and cards as well as standard sensors, a switchable power supply (Power Distribution Unit - PDU) including its battery packs, a radio telemetry / telecommand system including its industrial gigabit ethernet switch (unmanaged, 8x ports, RJ45), a high-sensitivity Inertial Measurement Unit (IMU), and the Drop Tower Sensor Pack (DTSP). The SCE is assembled with its main components altogether to the capsule base structure at the bottom of each capsule. The radio telemetry / telecommand system for drop or catapult operation is located at the inner plate of each capsule lid. It provides an industrial wireless local area network transmission path with a transfer rate up to 450 Mbit/s. In case of GraviTower operation, the radio telemetry / telecommand system is placed at the top of the actually installed standard capsule structure. GraviTower's local area network system makes use of an industrial Li-Fi (Light Fidelity) network providing a secured optical and wireless transmission path with a transfer rate up to 250 Mbit/s.

➔ **Important note: The Standard Capsule Equipment (SCE) is a mandatory unit for operating the Bremen Drop Tower or the GraviTower Bremen Pro.**

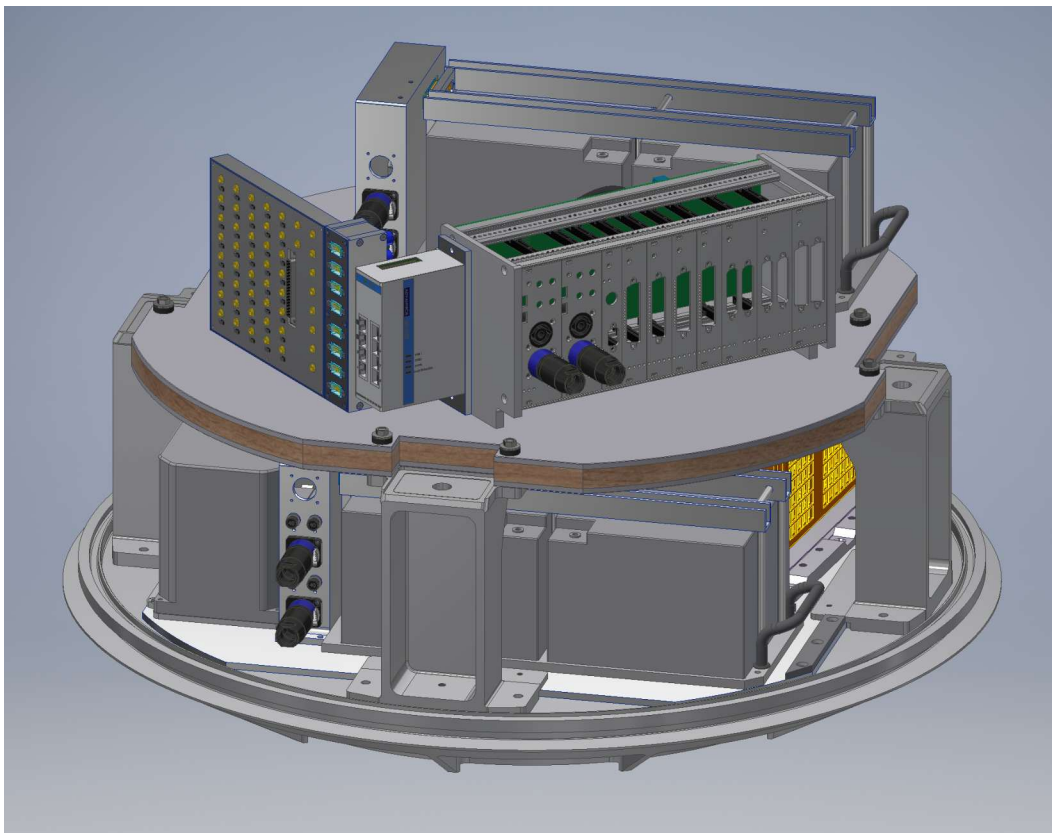

Figure 5.1: The Standard Capsule Equipment (SCE) is accommodated at the bottom of each drop tower capsule.

5.1.1 - Capsule Control System

After integration of the experimental setup into the mechanical structure, the drop tower experiment is electrically connected to the Capsule Control System (CCS), in order to conduct required communications and operations like triggering, signaling, switching, data acquisition and handling. The connection between experiment and CCS is based upon a National Instruments™ Real Time PXI System providing sufficient analog and digital I/O channels plus serial communications as well as relay / MOSFET switches for that purpose. The Laboratory Virtual Instrument Engineering Workbench (LabVIEW™) software, a visual programming language from National Instruments™, is used to program the experiment control in a dedicated sequence for drop, catapult, or GraviTower mode. During the capsule integration process, the responsible drop tower engineer performs the LabVIEW™ programming conforming to specifications given by the experimenters. Afterwards, intensive ground testings are accomplished at the Electronic Ground Support Equipment (EGSE) to qualify the overall integrated capsule setup before operation begins in the drop tube from the control room or in the GraviTower from the control desk.

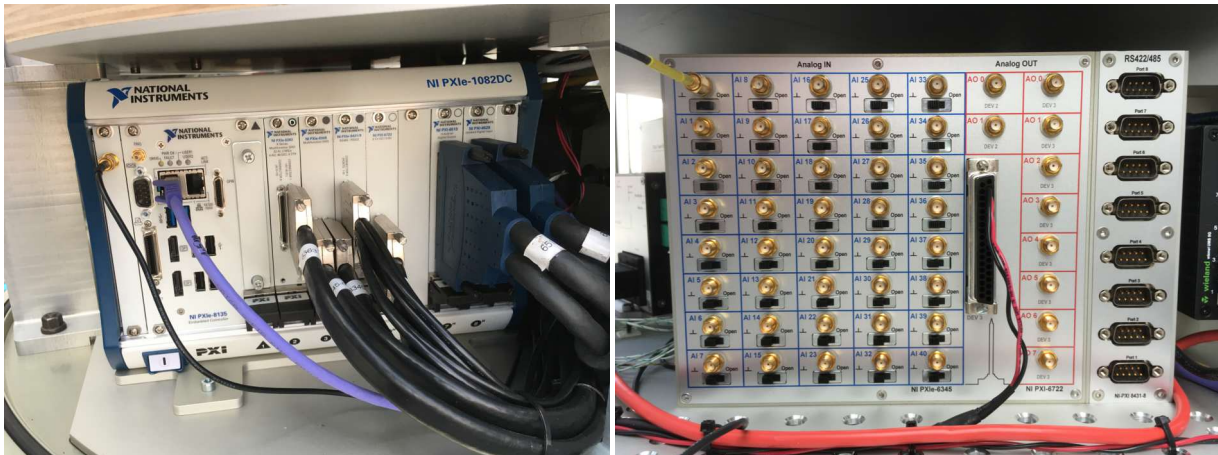
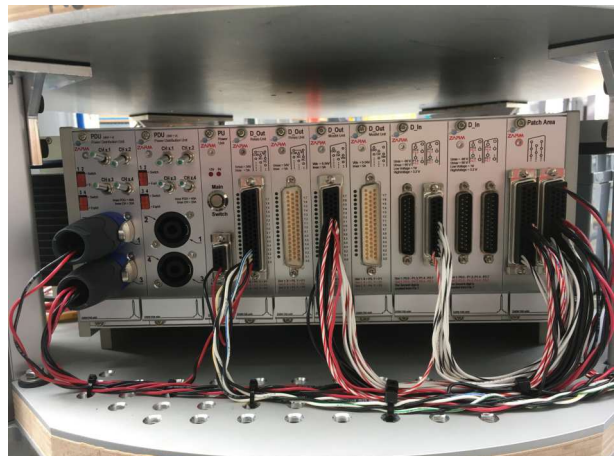

Figure 5.2: National Instruments™ Real Time PXI System [left] including its analog I/O (female SMA connectors) and serial RS-485/RS-422 (male D-sub connectors) interface board [right].

5.1.2 - Battery Packs and Power Distribution Unit

During all transfers and during the in-flight operation, each capsule is supplied with electrical power from two stand-alone on-board rechargeable battery packs - one to supply internal capsule units like the CCS, the other one to supply the experiment via 8x switchable power lines of the on-board Power Distribution Unit (PDU).

Figure 5.3: Location of the two PDU slide-in modules in the power and interface rack [leftmost]. This rack also accommodates CCS' digital I/O interface cards including relay / MOSFET switches (male D-sub connectors).



➔ **Important note:** Each battery pack (regular lead-acid types) for internal capsule units and respectively the experiment has a nominal voltage of 24 V DC and a nominal capacity of 25 Ah. Both battery packs are recharged during ground operation at the EGSE or during drop/catapult/GraviTower operation at the specific capsule docking system. The overall charging voltage is 27.6 V DC. During charging or also discharging, the actual output voltage by the PDU may allow a tolerance from 22.6 to 30 V DC. Thus, please consider that DC / DC converters with a wide input range, e.g., from 18 to 36 V DC, are strongly recommended on the experiment side.

Electrical interface and performance of both slide-in modules of the on-board Power Distribution Unit (Figure 5.3):

- 8x locally or remotely switchable power lines distributed over 4x Neutrik SPX Series connectors (NL4FX)
- up to 15 A output current per single power line (up to 20 A for a short time upon special request)
- not more than 30 A output current per Neutrik SPX Series connector or PDU slide-in module
- nominal 24 V DC (27.6 V DC while charging) output voltage per single power line (tolerance: 22.6 - 30 V DC)
- max. 1500 W of total electrical power consumption by the experiment (supplied by on-board battery pack)

➔ Please note: Additional batteries (various types) may be accommodated in the payload area, after consultation.

➔ **Important note:** Hardware devices requiring AC voltage should be avoided in the experimental setup. If no other option with DC-powered devices is feasible, non-standard DC / AC converters can be provided as an **Additional Capsule Equipment (ACE)** in the payload area on demand (please refer to section 5.2.4).

In terms of the ground concept, all electrical grounds of the embedded SCE units, e.g., grounds of CCS devices and the radio telemetry / telecommand system, any conductive housings and body parts, as well as the overall capsule structure itself are connected to the ground of that battery pack, which supplies those internal capsule units. According to the needs of the experiment, there are two options to electrically implement the experimental setup:

A. Non-Isolated Experiment Connection (Recommended)

All device grounds of the experimental setup are connected to the ground of the experiment battery pack. Each conductive housing and body part of the setup has a grounding connection to the capsule structure. By default, the PDU directly interconnects both grounds of the battery packs (internal capsule units and experiment) in such a non-isolated configuration via an internal jumper.

or

B. Isolated Experiment Connection

All housing and body parts of the experimental setup have no conductive connection to the capsule structure in any way. Each ground of all setup devices is directly interconnected to the ground of the experiment battery pack. Please consider that analog outputs are always referenced to CCS' ground and thus cannot be used in such an isolated configuration. Additionally, the jumper interconnecting both grounds of the battery packs in the PDU must be removed to separate the experiment battery pack ground from the battery pack ground for the internal capsule units.

5.1.3 - Electrical Interface Board and Cards

In order to realize communications and operations between experiment and the CCS, different types of connections are available via the on-board interface board and cards (Figure 5.2 [right] and 5.3). The following list gives an overview of the possible standard connections provided by the CCS:

| Port Identity | Connection Type | Quantity | Description |
|--|--------------------------------------|----------|--|
| analog inputs | female SMA (SubMiniature Vers. A) | 40x | input range: ± 10 V sampling rate: 100 Hz ... 10 kHz (differential, 16-bit resolution) |
| analog outputs | female SMA (SubMiniature Vers. A) | 10x | output range: ± 10 V (max. ± 5 mA per channel) update rate: 1 Hz ... 100 Hz (max. 5 kHz) (referenced to CCS ground, 13-/16-bit resolution) |
| serial communications | male D-sub (8x DE-9) | 8x | standards: RS-485 / RS-422 baud rate: 75 baud ... 3000 kbaud |
| | male D-sub (1x DE-9) | 1x | standard: RS-232 (by NI™ Real Time PXI System) baud rate: 75 baud ... 115200 baud |
| digital inputs | male D-sub (4x DB-25) | 48x | input high voltage: +3.2 V DC to +60 V DC input low voltage: -60 V DC to +1 V DC (isolated, max. ± 3 mA per channel) |
| digital outputs (relay switches) | male D-sub (2x DD-50) | 32x | switchable voltage: max. 250 V DC (max. 5 A per channel) |
| digital outputs (MOSFET switches) | male D-sub (2x DD-50) | 32x | switchable voltage: max. 55 V DC (max. 5 A per channel) |

➔ Please note: Appropriate data and commands throughout those communication lines are continuously logged with a common sampling rate of 1 kHz (400 Hz for the iIMU-FCR-03 - please refer to section 4.1.5) and stored in consecutive TDMS (Technical Data Management System) files on the CCS during ground or drop tower operation. Every minute, the CCS will automatically generate a new TDMS file. Each of those single TDMS files contains all needed log and measurement information. If desired, a selection of consecutive TDMS files can be merged to one single file and also exported to another format, e.g., to the common ASCII (American Standard Code for Information Interchange) format.

➔ **Important note:** By means of the CCS, desired or even all analog and digital input / output data of the communication lines as well as any data from the serial communications can be made available in situ. Those continuously logged data will be displayed on the ground control computer at the EGSE and respectively in the control room for experimenter's instantaneous analysis. If needed, the LabVIEW™ software programming of CCS' experiment control also allows to create dependences and interactions of actual sensor as well as input / output data with the drop tower experiment.

5.1.4 - Standard Capsule Sensors

The standard sensors of each drop tower capsule, which are arranged in one multi-sensor unit, are permanently connected to the CCS through one serial communication port of its interface board, in order to provide standard environmental capsule data during ground and respectively drop tower operation. The sensor data are continuously stored on the CCS. The utilized multi-sensor unit is a LI65+ type manufactured by Thermokon Sensortechnik GmbH.

The LI65+ multi-sensor by Thermokon Sensortechnik GmbH provides following measurements in each capsule:

- **temperature: -20 °C to +80 °C (default range) with an accuracy of ± 0.5 K (typ. at 21 °C)**
- **pressure: 500 ... 1500 hPa (0.5 ... 1.5 bar)**
- **humidity: 0 ... 100 % rH non-condensing with an accuracy of ± 2 % between 10 ... 90 % rH (typ. at 21 °C) (absolute humidity and dew point are internally calculated)**
- **light: 0 ... 1000 Lux (default range) with an accuracy of ± 50 Lux (± 5 % of measuring range)**

5.1.5 - Inertial Measurement Unit

A high-sensitivity Inertial Measurement Unit (IMU) is accommodated in each capsule as a further Standard Capsule Equipment (SCE) and a mandatory unit for drop tower operation, respectively. The utilized low-noise IMU is manufactured by ASC (type: ASC IMU 7.050LN.075). Its connection to the CCS is established over a 12-pin Comtronic (male) connector. Similar to the data acquisition of the standard capsule sensors as well as the experiment data and commands, all logged IMU data are stored on the CCS.



Figure 5.4: The ASC IMU 7.050LN.075 (z-axis corresponds to capsule axis).

The ASC IMU 7.050LN.075 provides precise angular rate and acceleration measurements:

- **gyroscope (3-axis) with an angular rate of ± 75 °/s**
- **acceleration (3-axis) with a sensor range of ± 50 g**

5.1.6 - Drop Tower Sensor Pack

Once the Drop Tower Sensor Pack (DTSP) is activated, it permanently records data from its different sensor types, logging the inner capsule environment. The DTSP is a complementary unit of the Standard Capsule Equipment (SCE), but only dedicated to internal purposes. On special request, its data can be made available to the experimenters.

5.2 Additional Capsule Equipment

Upon a special request, Additional Capsule Equipment (ACE) can be provided for the drop tower campaign on site. Furthermore, equipment that is not listed in this section could be made available for the experimenter as well. In any case, experimenters are strongly encouraged to contact ZARM FAB mbH evaluating the best equipment option.

5.2.1 - High-Speed Camera Systems

Six units of the "Phantom Miro™ C321 - 16GB" compact cameras are available to enable higher resolution imaging. The performance of the "Phantom Miro™ C321 - 16GB" camera is listed below:

- camera size (73 mm x 73 mm x 87.2 mm; 540 g; without lens)
- CMOS sensor (22.03 mm diameter) with 10 μm pixel size
- 1920 x 1080 pixel resolution
- 1,480 f/s recording rate at full image resolution and 4.48 s recording time
- 94,510 f/s recording rate with minimum image resolution of 640 x 8 pixel and 28.4 s recording time
- 240 GB Cine flash memory (internal data storage)
- global shutter with minimum exposure time of 1 μs
- options for hardware and software trigger
- color or monochrome (10 bit)
- lens mount: 1" C-mount
- lenses: 12 mm and 18 mm focal length
- ethernet camera control via CCS (LabView™) or Phantom PCC (Windows x64) Software™
- saved file format: Phantom Cine RAW (.cine) and converted formats MP4, AVI, TIFF, JPG, DNG and more

➔ Please note: The "Phantom Miro™ C321 - 16GB" camera is equipped with a fan. To prevent any disturbances to the microgravity quality, it is recommended to switch off the fan during operation in microgravity.

➔ Please note: Since the "Phantom Miro™ C321 - 16GB" is equipped with a large local memory, several recordings can be saved during the experimental phase. Thus, the camera is very well suited for GraviTower operation.



Figure 5.5: High-speed camera system "Phantom Miro™ C321 - 16GB".

Additionally, up to 3 units of the robust high-speed camera system “Photron FASTCAM MC2™” with one or two remote camera heads are available. Each camera head offers a light sensitive CMOS imaging sensor. An overview of the performance of the Photron FASTCAM MC2™ system is listed below:

- up to two remote camera heads (35 mm x 35 mm x 35 mm; 90 g; without lens)
- 512 x 512 pixel resolution
- 2000 f/s recording rate at full image resolution, for both camera heads and 4 s recording time
- 1000 f/s recording rate at full image resolution, for both camera heads and 8 s recording time
- up to 10.000 f/s with reduced image resolution (512 x 96 pixel)
- global electronic shutter from 20 ms to 6 μ s
- color (24 Bit) or monochrome (8 Bit)
- lens mount: C-mount
- a variety of lenses is available - focal lengths: 8.2 mm, 12.7 mm, 17.6 mm, 22.5 mm, 29.3 mm
- remote camera heads with 3 m cable allows easy positioning at hardly accessible space
- processor unit (H: 195 mm x W: 159 mm x D: 130 mm; 5 kg)
- camera heads are precisely synchronized to an external source
- start, end, center and manual trigger modes
- live video during recording: NTSC, PAL
- ethernet camera control via CCS or Photron FASTCAM Viewer (PFV) Software™
- saved image formats: JPEG, AVI, TIFF, BMP, RAW, PNG, MOV, and FTIF

➔ Please note: The live video output of the Photron FASTCAM MC2™ system can be transmitted from the drop or catapult capsule to the control room, while the capsule is in the drop tube and has a direct optical connection to the infrared video transmission system on top of the drop tube. In this way, a live video output is feasible prior to the microgravity experiment and during free fall. The bandwidth of the transmitted data is standard video. The high-speed camera data are still stored on the processor unit as usual, which is onboard the experiment capsule.



Figure 5.6: High-speed camera system “Photron FASTCAM MC2™” .

5.2.2 - Heating and Cooling Circuit

Each experimental setup can be connected to a thermal liquid circuit during its ground operation at the EGSE or during its drop tower and respectively GraviTower operation at the related capsule docking system. In the drop tower case, the experiment capsule is connected to a thermostat outside of the drop tube via a vacuum-capable thermal liquid line. The circuit must be disconnected about one minute prior to the drop command in drop mode or about 10 minutes prior to the launch command in catapult mode. In the GraviTower case, a disconnection of the thermal liquid circuit must take place prior to each launch command. The final timing must be in accordance with the required GraviTower procedures launching the slider. After each run, a reconnection of the circuit is immediately feasible.

Technical data and performance of the thermostat are shown below:

- *forerun temperature:* -20 °C to +60 °C
- *liquid:* glycol/water-mixture
- *heating power:* max. 2 kW
- *cooling power:* 2.3 kW at +20 °C / 1.2 kW at -20 °C
- *volume of bath:* 19 l to 27 l
- *max. pressure:* 0.6 bar

➔ Please note: Through a closed loop regulation, the temperature can be adjusted between -20 °C and +60 °C. An onboard heat exchanger with about 1 kW of power (forerun temperature dependent) can be also made available, in order to heat or cool a dedicated experiment area in the drop tower capsule.

5.2.3 - Non-Standard Power Supply

A high current power supply, to be used as an external power supply providing max. 28 V DC with up to 100 A, can be provided during ground operation at the EGSE or during drop tower and respectively GraviTower operation at the related capsule docking system. The power supply, e.g., to heat an experimental furnace in the experiment capsule, must be disconnected about one minute prior to the drop command in drop mode, about 10 minutes prior to the launch command in catapult mode, or in accordance with the required timing prior to each launch command in the GraviTower mode. In all cases, the switching of current is performed with ramps.

5.2.4 - Non-Standard DC / AC Converters

Two non-standard DC / AC converters with electrical output powers of 150 W (230 V AC) and respectively 600 W (230V AC) are available on special request and can be additionally implemented in the payload area.

➔ **Important note: In general, AC voltages should be avoided in the experimental setup, in order to prevent unexpected electronic noise or related electrical issues in any data acquisition or other technical systems used (please also refer to section 4.1.2).**

5.2.5 - Capsule Vent Line

In order to release gases out of the drop tower capsule during its operation under the vacuum conditions inside the drop tube, e.g., from cryogenic devices or combustion exhausts of the experimental setup, an internal vent line inside the capsule can be provided. This vent line will be connected to a valve at the capsule lid.

- ➔ Please note: The capsule vent line can be also used to evacuate a vacuum-capable vessel of the experimental setup to the ambient vacuum of the drop tube during the drop tower operation.

- ➔ **Important note: In order to avoid thruster effects during free fall, the valve of the vent line at the capsule lid must be closed prior to the release or the launch of the drop tower capsule. For safety reasons, this valve must be controlled by the Capsule Control System (CCS). Once the valve of the vent line is closed, all gases must be stored in capable onboard containers which are part of the experimental payload. A capable onboard container storing gases in the payload area is also strongly recommended in terms of GraviTower operation. In this case, a secured and controlled venting of gases is feasible between runs. While the experiment capsule is in the flight phase, thruster effects must be avoided in the GraviTower as well.**

6. ENVIRONMENTAL CONDITIONS

6.1 Pressure Environment

Each drop tower capsule covered with its shell and lid during drop tower operation is a gas-tight and pressure-tested vessel, sealing the interior from the outer vacuum in the drop tube. The interior is kept on atmospheric conditions throughout the entire drop tower procedure. The inner pressure of each capsule is permanently monitored as part of the housekeeping data measurements - please also refer to section 5.1.4.

Below values are valid for a sealed capsule configuration with its shell and lid during drop tower operation.

- *nominal capsule pressure:* $p = 1013 \text{ hPa}$
- *pressure loss over time:* $\Delta p < 1\% \text{ within } 3 \text{ h}$
- *pressure safety values:* $980 \text{ hPa} < p < 1.300 \text{ hPa}$

➔ Please note: Deviations off the nominal capsule pressure may result from a temperature shift due to differences of the ambient temperatures between the integration area and the top of the drop tube at a height of 120 m, e.g., in case of a drop experiment. In this context, seasonal temperature variations shall be considered as well.

➔ **Important note: In case of high pressure rises in the fully closed capsule during drop tower operation, e.g., due to outgassing experimental vessels, the overpressure is released over the capsule vent line (see section 5.2.5) to its environment. A pressure release is not valid during free fall. Capable gas containers must be considered in the experimental setup for such a potential event. The detection of a high or low capsule pressure out of its safety values always leads to an abort of the drop tower operation.**

6.2 Thermal Conditions

The nominal capsule temperature is in general **room temperature**. It may shift about some kelvin due to seasonal variations depending on differences of the ambient temperatures between the integration area and the top of the drop tube, in case of a drop experiment. In wintertime, the ambient temperature can even drop to a few degree centigrade inside the drop tube at a height of 120 m, for instance. Finally, drop experiments sensitive to temperature shall be heated or cooled by the heating and cooling circuit - please also refer to section 5.2.2.

Depending on the experimental setup integrated inside the drop tower capsule, the nominal capsule temperature may vary during drop tower or GraviTower operation as well. As part of the housekeeping data measurements, the capsule temperature is permanently monitored - please also refer to section 5.1.4. Additionally, the CCS offers the capability to perform further temperature measurements at different locations in the payload area, if desired.

➔ Please note: Any thermal power loss of electrical devices installed inside the fully closed capsule leads to an increase of the overall capsule temperature during drop tower operation. In terms of planning a temperature-sensitive drop or catapult experiment, a pre-analysis of the total thermal power loss generated by all utilized experiment components is recommended. The heating and cooling circuit (section 5.2.2) offers a further option.

6.3. - Acceleration / Deceleration Plots - Drop Mode

The Bremen Drop Tower offers three operation modes for experimenting in a high-quality microgravity environment. The drop mode is used for experiments that can be performed within 4.7 s in microgravity and/or require a 1 g to microgravity - transition.

- ➔ Please note: The release mechanism to drop experiments are designed for a smooth transition from 1 g to microgravity, in order to minimize structural vibrations during release.
- ➔ Please also note: An acceleration of up to a peak value of about 50 g must be considered during the capsule deceleration in the deceleration container.

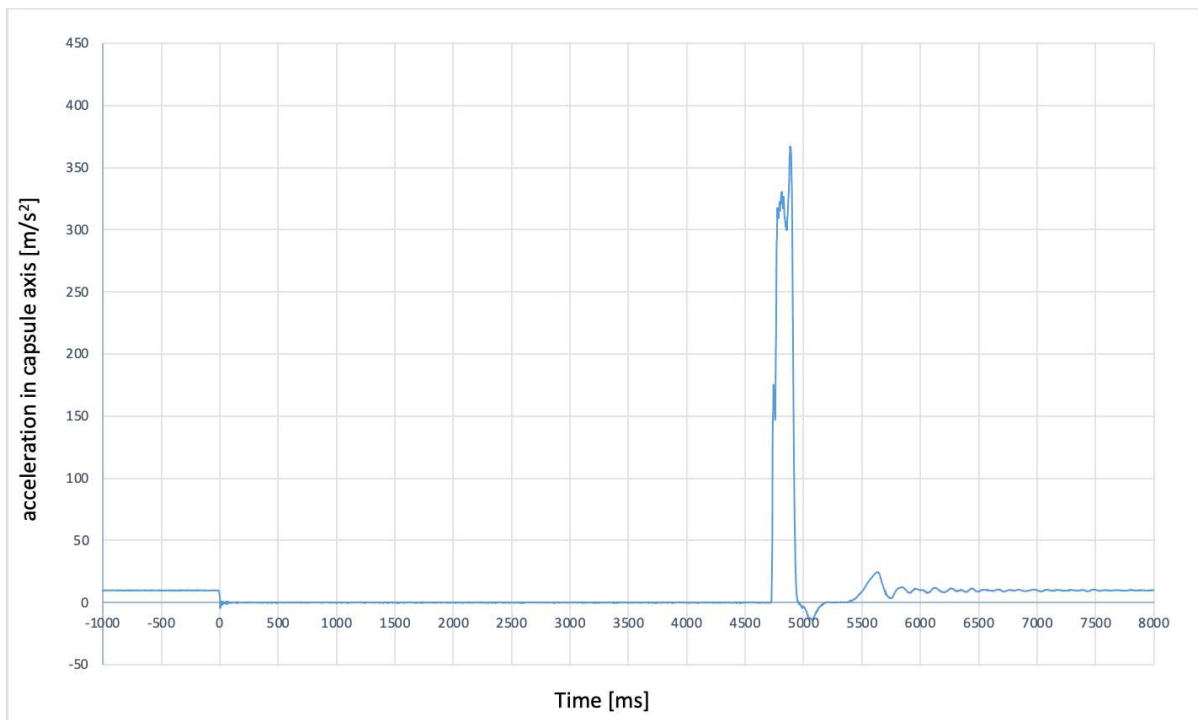

Figure 6.1: Example for a generic data set of a drop measured with the IMU "iIMU-FCR-03".

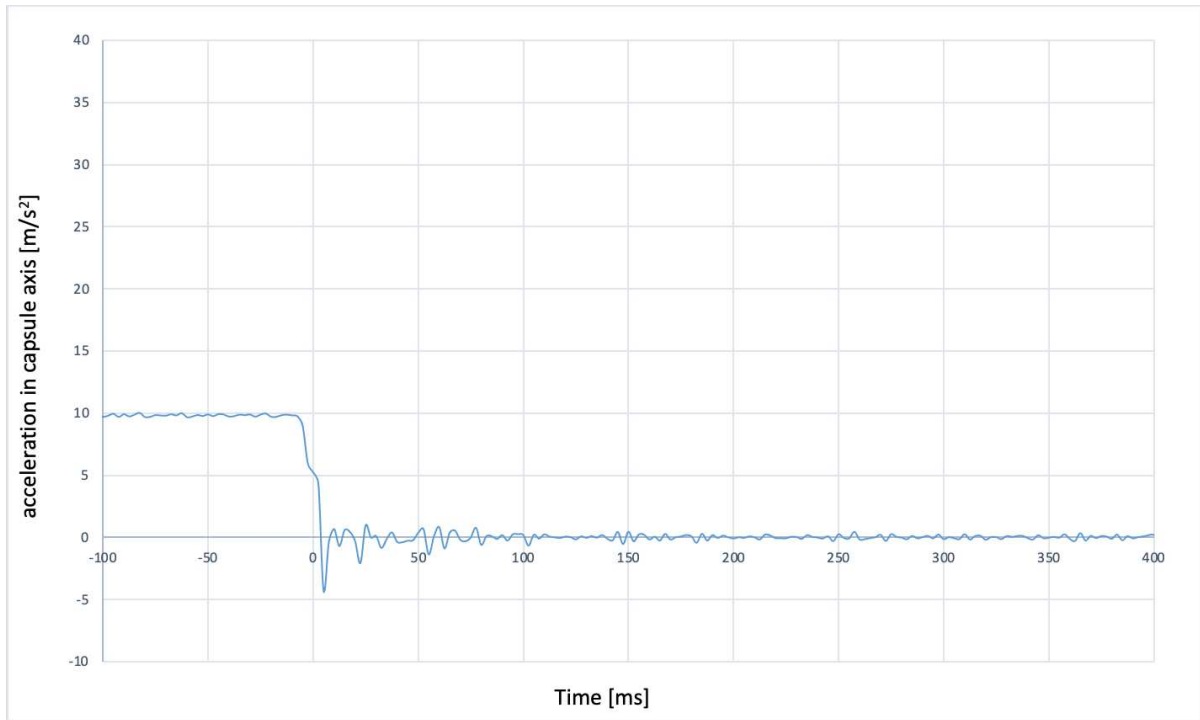

Figure 6.2: Zoom-in of the capsule release during the drop (same data set - Figure 6.1).

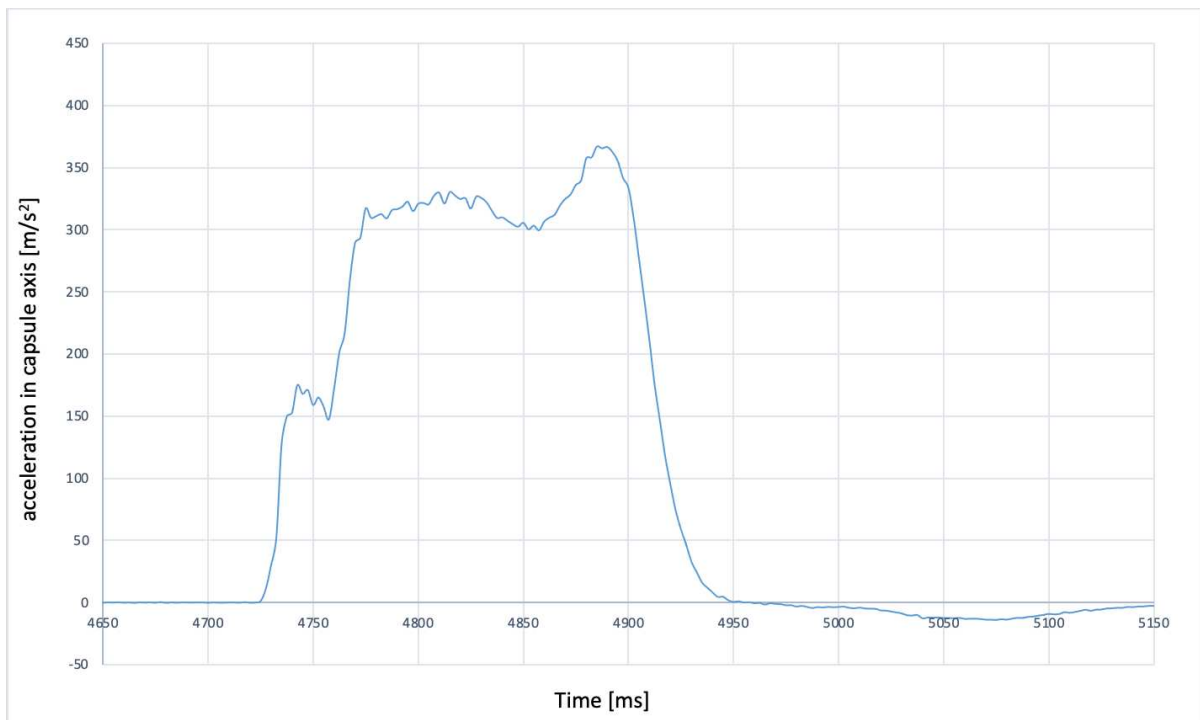

Figure 6.3: Zoom-in of the deceleration profile (same data set - Figure 6.1).

6.3. Acceleration / Deceleration Plots - Catapult Mode

The catapult mode is used for experiments that require a longer microgravity period of up to 9.3 s, which is actually unmatched by any other drop tower systems worldwide, and can be performed with an initial acceleration of approx. 30 g.

- ➔ Please note: The launch mechanism of the catapult system is designed for a smooth transition from the acceleration phase to microgravity, in order to minimize structural vibrations during the launch.
- ➔ Please also note: Comparable to the drop modes, an acceleration of up to a peak value of about 50 g must be considered during the capsule deceleration in the deceleration container.
- ➔ Please note: Single periods of microgravity may vary some milliseconds from flight to flight in the catapult mode (up to 9.3 s). It depends on the actual pneumatic pressure that is applied for the specific capsule launch. Pressure adjustments can be made. But, a safety margin in distance must be strictly adhered to the top of the drop tube.

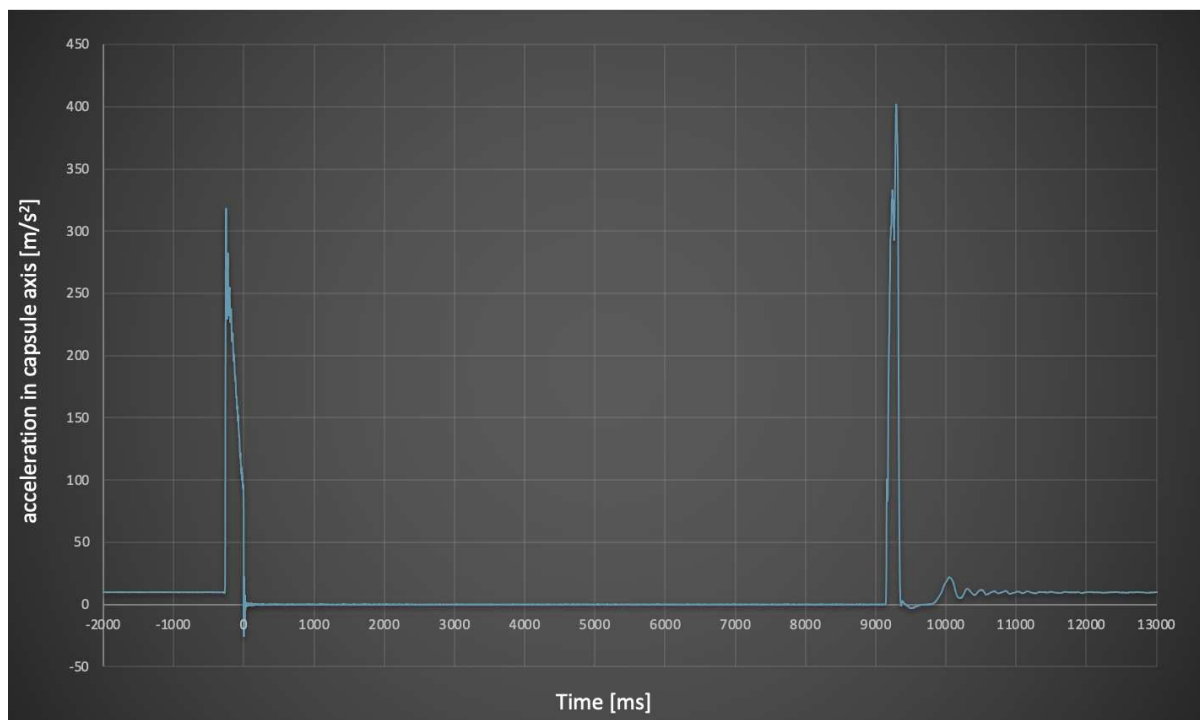

Figure 6.4: Example for a generic data set of a catapult flight measured with the IMU "iIMU-FCR-03".

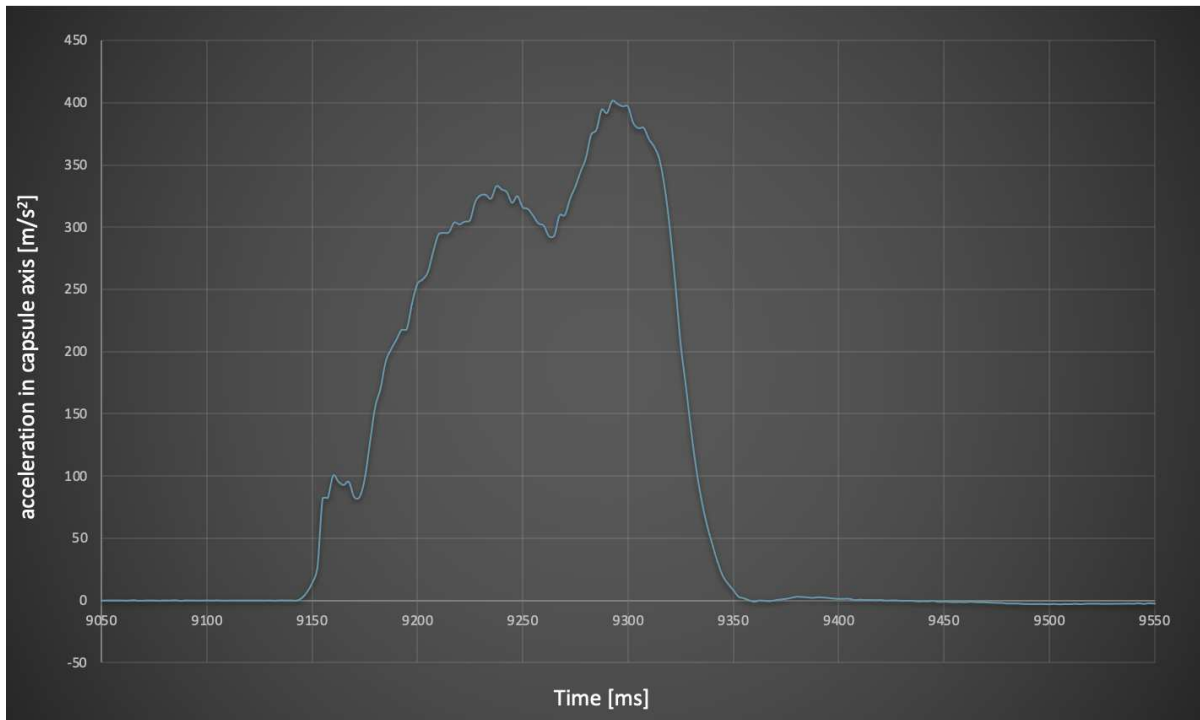

Figure 6.5: Zoom-in of the initial acceleration profile during the catapult launch (same data set - Figure 6.4).

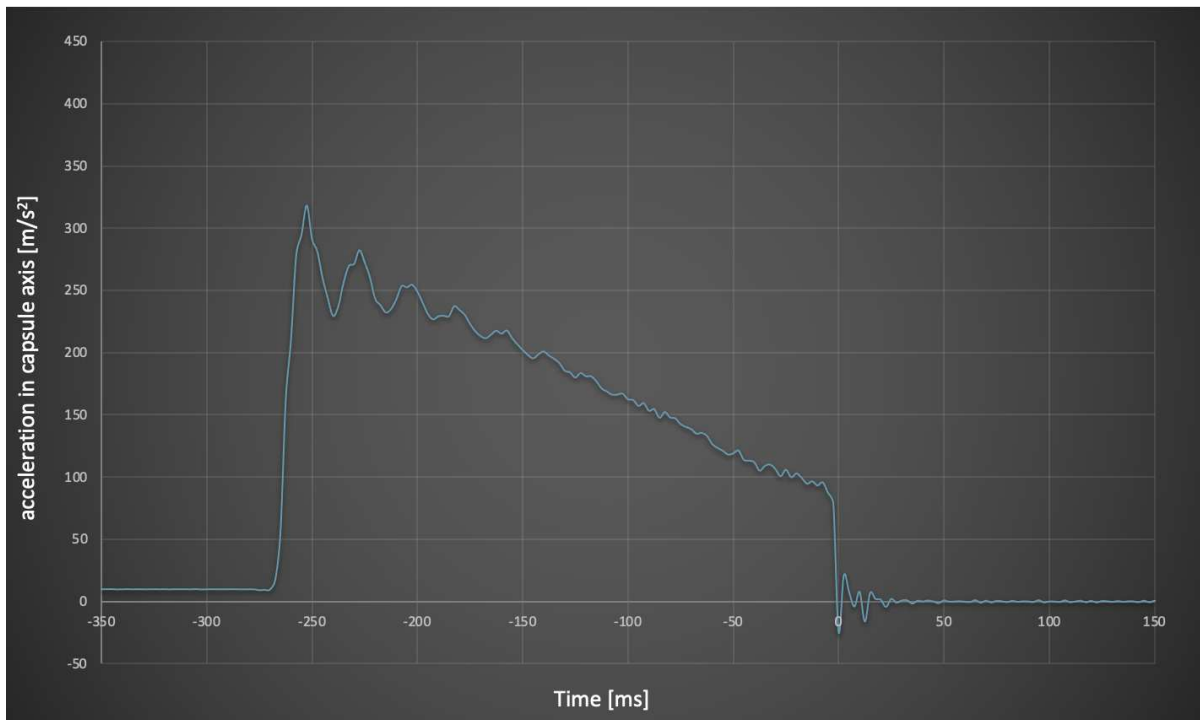

Figure 6.6: Zoom-in of the deceleration profile (same data set - Figure 6.4).

6.3.3 - Acceleration / Deceleration Plot - GraviTower Mode

The GraviTower mode is used for experiments within max. 2.5 s in microgravity that shall benefit from higher repetition rates with up to 960 feasible experiments a day. Furthermore, the GraviTower is preferred for experiments which require adjustable kinematics of up to 5 g acceleration as well as up to 5 g deceleration in total in order to explore a wide range of parameters. This is important to test preliminary setups or appropriate experiment components, to qualify foreseen hardware or new technologies for space missions, or to facilitate dedicated microgravity research with reliable statistics.

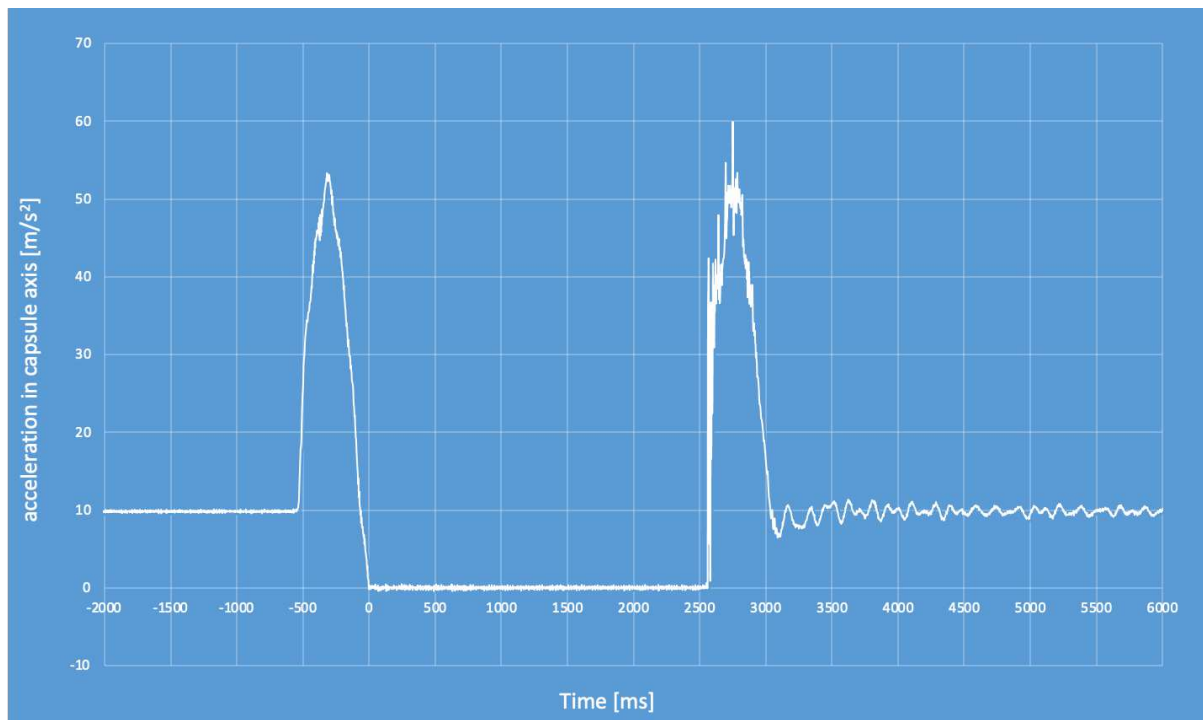

Figure 6.7: Generic data set of a GraviTower run measured with the IMU "iIMU-FCR-03" - parameter set of acceleration and deceleration with max. microgravity duration.

- ➔ Please note: With its patented Release-Caging-Mechanism (RCM), the actively driven GraviTower is capable to realize a very smooth and precise experiment transition into the microgravity phase. All related kinematics and thus the profiles of the initial acceleration and the later deceleration are individually adjustable in their amplitudes. For fine tuning the release of the capsule into the free fall phase, even the final acceleration profile (lower radius) can be separately adjusted to identify the best parameter for the related experiment - please also refer to section 2.2.2.
- ➔ **Important note: All experimental payloads must be designed and mounted enabling to withstand the acceleration / deceleration forces - please refer to the section 5.1.3 and section 5.1.4.**

- ➔ Please note: Several adjustments of GraviTower's kinematic parameters by the experimenters (or in the future even by artificial intelligence) are possible (see Figure 2.10) - the related microgravity duration will be automatically calculated by the system.

6.3.4 - Quality of Microgravity

The quality of microgravity or the residual acceleration is of the order of 10^{-6} g during each flight in the drop or catapult mode. This level is one of the best values amongst the available microgravity platforms. Due to the low vacuum level of a few pascal inside the drop tube, similar high-quality microgravity and thus experiment conditions are achievable from flight to flight.

In order to proof such a high-quality condition of weightlessness, high-sensitivity accelerometers are required. Those devices are non-standard equipment. Special reference measurements revealing the microgravity quality took place at the Bremen Drop Tower, e.g., for the preparation of the MICROSCOPE space mission.

For detailed information about the accelerometers of the MICROSCOPE mission and the measured quality of microgravity in the drop as well as catapult mode, please refer to following publications:

- *F. Liorzou et al., "Free fall tests of the accelerometers of the MICROSCOPE mission", Advances in Space Research 54 (2014) 1119-1128*
- *F. Liorzou et al., "MICROSCOPE instrument description and validation" Class. Quantum Grav. 39 204002 (2022)*

- ➔ Please note: Preliminary measurements of the residual acceleration, have already taken place during several dedicated test runs in the GraviTower mode. At the current stage of development of the GraviTower, it can be stated that its proven quality of microgravity is of the order of below 10^{-4} g.

7. SAFETY

A risk assessment for each drop tower experiment is essential and must be conducted before starting work at the Bremen Drop Tower. The risk assessment is the responsibility of the experimenters and is therefore mandatory.

As a general guideline, the safety requirements for performing experiments in the Bremen Drop Tower or in the GraviTower Bremen Pro in a safe and successful manner do not exceed those that are applied to an experiment operation in one's own or in a typical research laboratory. It might be understood that the experimenters are responsible to care for a safe operation of their equipment and to implement effective safeguards into the experimental setup.

➔ **Important note: The experimenters shall examine all of their equipment, which will be brought to ZARM's premises, to identify potential hazards. ZARM FAB mbH must be informed about any potential hazards in due time, in order to enable the installation of appropriate countermeasures.**

The safety requirements to be applied are summarized below:

- *Gaseous fuels and oxidizer must be stored in different containers. Ignitable pre-mixture storage is prohibited.*
- *There are no general pressure limits for gas reservoirs. But, pressurized reservoirs used must be certified by the technical survey of the experimenters' country. In the case, this does not exist or the request is inappropriate, the experimenters must be able to handover the technical standards of related design calculations, on request.*
- *If hazardous gases are used, an appropriate gas detector to monitor leakages must be part of the setup.*
- *The release of toxic, corrosive, explosive, bio-hazardous, or elsewhere contaminating matter into the capsule or to the outside of the capsule is prohibited. The experimenters are in any case requested to declare potential hazards for the drop tower operators' safety.*
- *Solenoid valves must be implemented into pressurized liquid circuits containing hazardous matter. The valves must be powerless closed. The switching power of the valves are connected to the PDU with a microgravity switch. In case of CCS failure, the valves can be closed by flying the capsule.*
- *Batteries must be of the solid-, dry-, or gel-type. Liquid electrolytic batteries will be refused.*

- *The center of gravity of the setup shall be on the vertical axis of the capsule. Slight deviations from that can be compensated on site through attaching passive counterbalance masses to the stringers. If this is impossible, because of place or exceeding the maximum mass of the capsule, the experiment can be refused. Please make sure that the masses are evenly distributed overall.*
- *Change of motion of masses during free fall shall be avoided. If this cannot be achieved, accelerations must be compensated by accelerating counterweights on or around the identical axis. Please consider the fact that you do not know about the exact location of the COG of the complete capsule in no direction. In case of doubt, a pendulum test of the fully integrated capsule can be made on site.*
- *Experiments that are mechanically weak and cannot be reinforced on site will be refused. So, please care for your equipment matching the conditions given by the mechanical requirements.*
- *Any electric element (valves, detectors, etc.) subjected to hazards or hazard control must be connected to the CCS. As any computer, the CCS is not totally failsafe. Therefore, the experiment shall be designed as failsafe as possible, in general.*

➔ **Important note:** If potential hazards are not reflected above, it does not necessarily mean that those hazards do not exist. The clearance to proceed with the drop tower experiment is subjected to continuous risk assessments during the capsule integration process and a final safety check prior to each flight, which are conducted by drop tower engineers together with the experimenters in both cases. It may lead to a request for remedial measure. In general, all experimenters are strongly encouraged to address any technical details of their experiments to ZARM FAB mbH for feasibility and safety checks, in advance. Finally, ZARM FAB mbH's aim is still to assist all experimenters with the best performance and make each drop tower experiment a success.

-----END OF DOCUMENT-----